

XTP601 Series

Oxygen Analyzer for Safe or Hazardous Areas

A robust, linear and stable oxygen analyzer for measurements in gases such as hydrogen, nitrogen or CO₂. The sensor is housed in a rugged casing, making it suitable for a wide range of applications. When the flame arrestors are fitted, the analyzer becomes explosion-proof and suitable for hazardous areas.



Highlights

- Compact and rugged design with an EExd enclosure and isolated 4-20 mA output
- ATEX, IECEx & cCSA_{US} Hazardous Area certified
- Touch-screen display allows calibration or adjustment without the need for a hot works permit
- Excellent accuracy of better than 1% full scale
- Zero span stability better than 0.25% of span per month
- Increased protection against contamination due to cell design
- Low cost of ownership due to minimal maintenance
- Ranges available: 0-1% up to 0-25% & 80 or 90-100%

Applications

- Oxygen measurement at inlet of compressors in steel or gas industries to monitor safety
- Biogas, waste, landfill and digester plants
- Inert gas for pharmaceutical or chemical industries
- Monitoring inert blanketing gases in oil tankers
- Furnace gas control in steel industry
- Hydrogen coolant in electricity turbines
- Catalyst regeneration
- And many more...

Michell XTP601 Oxygen Analyzer for Safe or Hazardous Areas

When a process oxygen application demands high accuracy and stability, along with low maintenance cost; paramagnetic oxygen technology is usually preferred. If, in addition, the application calls for a rugged and reliable, corrosion resistant analyzer, the thermo-paramagnetic principle of Michell's new XTP601 series makes it the instrument of choice.

The XTP601 series oxygen analyzers from Michell Instruments are designed to measure the percentage of oxygen in process gases. Using thermo-paramagnetic technology, the sensor is reliable and highly stable. The XTP601 is housed in an explosion-proof case and is rated ATEX Zone 1 for use in hazardous areas. For installation in non-hazardous areas, a general purpose version is available.

Features

Excellent accuracy

Oxygen measurements are highly susceptible to pressure variations because they are generally based on the partial pressure of oxygen. For a non-corrected analyzer, a 1% change in atmospheric pressure will result in a 1% change in the reading. The XTP601 has barometric pressure compensation fitted as standard and is ranged specifically to customers' needs to offer the best accuracy where it matters. For instance, in a 0-1% range the XTP601 is accurate to $\pm 0.02\% \text{ O}_2$.

Higher sensor stability reduces calibration costs

The sensor in Michell's XTP601 analyzer largely eliminates thermistor drift associated with other comparable devices, improving the stability of the measurement. This allows longer calibration intervals and reduces both labor and consumable costs.

Reliable long-term performance

In some installations, such as offshore or on board oil tankers, the movement and vibrations present could affect the moving parts of other kinds of sensors. The thermo-paramagnetic sensor has no moving parts, making it ideal for these applications.

Non-depleting technology

The sensor does not require routine replacement and is not poisoned like electrochemical cells. This will save downtime and maintenance costs. The cell performance is consistent and does not drift as it is not consumed by the process.

The non-depleting sensor reduces service intervals and no regular replacement of cells is required. The casing unscrews to allow for easy access to the sensor, enabling maintenance of the modular components to be carried out quickly and efficiently.

Easy installation with local display for use in hazardous areas

The XTP601 provides two isolated 4-20 mA outputs and is housed in a robust and weather-proof casing, allowing the analyzer to be placed at the point of measurement.

The closer the analyzer can be installed to the sample point, the better, for many reasons. These include, faster overall speed of response (for safety), less sample line or cabling (saves cost) greater choice of installation points (flexibility). Also having a local display does not require two operators (or walking back and forth to the control room) for maintenance or diagnostics.

External sensor input

The unit has the facility to accept a 4-20 mA signal from an external source such as dew point sensor, pressure transmitter, temperature probe or user-defined sensor, and display it on the screen. This saves the cost of buying and installing an external display for another parameter that only requires occasional visual inspection.



Chemical plant

Technology Thermo-Paramagnetic Sensor

Oxygen is a paramagnetic gas, which means that it is attracted by a magnetic field. This magnetic susceptibility is much greater for O_2 than that of most other gas molecules and therefore this physical property is ideal for the determination of the level of oxygen in a wide range of background gases.

The XTP601 series is a thermo-paramagnetic oxygen analyzer where the combination of paramagnetic and thermal conductivity technology is exploited to accurately measure oxygen. The instrument is very stable which gives the user confidence in the measurement. This is important in safety applications such as blanketing of vessels or reactors in chemical plants.

In addition to the stability of the Michell XTP601 sensor, the insensitivity to mechanical shock is another advantage of the thermo-paramagnetic technology. As it relies solely upon fluctuations in magnetic fields and not internal moving parts, the sensor will operate efficiently under a wide range of environmental conditions. It is suitable for installation where vibration or movement could pose a problem for other sensor types.

Flexible Packaging

The XTP601 is available in three configurations all with the option of Safe (GP) or Hazardous (EX) Area classification depending on the individual customer's needs. This allows the user to determine the price to feature ratio that best suits each installation.



XTP601 (EX1 or GP1)
The full display model provides a local HMI for the user to access all the functions of the analyzer through the glass via capacitance buttons. As well as displaying the oxygen concentration there is a status bar showing messages. The user can scroll through the front screens to see a graph of the latest period (user defined), high & low oxygen points, reading from an external sensor and alarm history.



XTP601 (EX2 or GP2)
This is similar to the blind transmitter, but has a window with power and status LEDs (alarm and/or fault) following the NAMUR standard.



XTP601 (EX3 or GP3)
The basic model is a blind oxygen transmitter that provides 4-20 mA outputs, alarm relays & RS485 serial communications. There is application software included that allows the user to visualize and interact with the unit from their PC or control system. There is an optional light guide that will indicate that the unit is powered up and/or in alarm condition.



Application Software
The XTP601 analyzer is supplied with application software that will allow the user remote access to the unit. This includes displaying the oxygen concentration, alarms, graphs, changing parameters and even remote calibration.

OS601 Premium Sample Handling System for the XTP601

For a long, trouble-free life, oxygen analyzers invariably require a clean, dry gas that is free from particulates and at a suitable temperature and pressure. In the real world, the process gas to be measured almost never fulfils these requirements. Michell Instruments offer a complete solution for this problem: The XTP601 and OS601 Sample Handling System. This modular system is constructed in consultation with customers to ensure the best possible solution for each individual application.

Flow Schematic for O₂ in Bio Gas

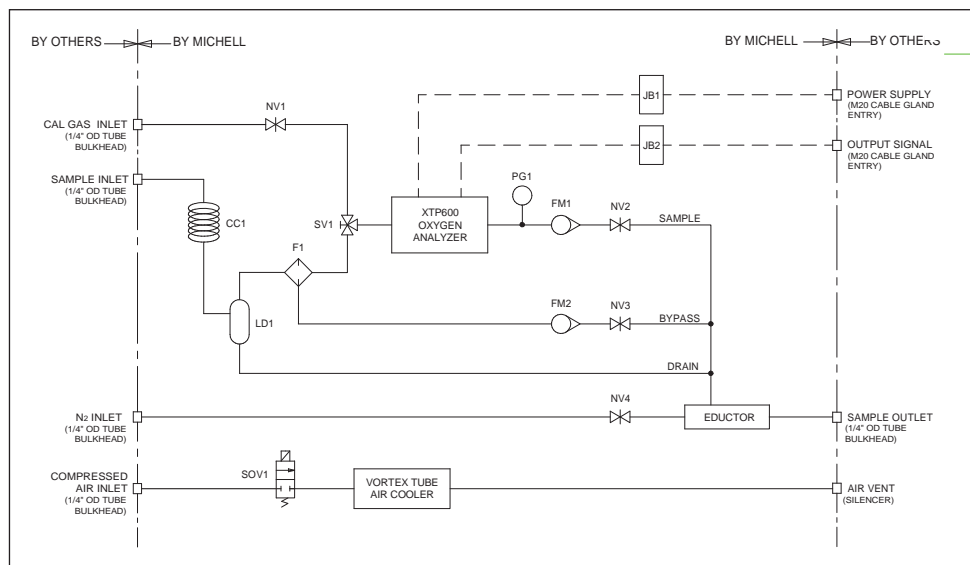

The sampling system shown is for use with "misty" gases sampled in a hazardous area. It is one of the more complex sampling systems available.

The use of an eductor negates the issues of using a pump with hydrocarbons and reduces cost. There is also a vortex cooler to keep the system cabinet cool.

